









---

**Precision machining & finishing** Synthetic Diamond Mechanical Range

# Taking unpredictability out of mechanical applications

Our range of single crystal and polycrystalline synthetic diamond products is subject to tightly controlled growth conditions and stringent quality control procedures. The result - an engineered material that is highly consistent and has predictable properties and behaviour required for cutting tool, wire drawing, dressing and super-finishing applications.

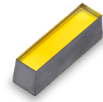
# Our comprehensive mechanical range

Area	Primary application	Product range	Crystal growth process	Product family	
Cutting tools and wear parts	Ultra precision machining acrylics, copper, germanium	MCC PT2	Single crystal chemical vapour deposition (CVD) diamond - Colourless (low nitrogen content)		MONODITE™ MCC
	Generates very high surface finishes	MCC PT4			
	Wide-ranging laser cut shape and size for precision machining of MMC and CFRP materials	CDM	Polycrystalline CVD diamond - Opaque (low nitrogen content)		CVDITE™
	Wide-ranging laser cut shape and size for precision machining of MMC, CFRP and woodworking materials	CDE			
Engineered cutting tools and wear parts for super-finishing burnishing and wire guides	Convenient cut shapes	MT L (rectangle)		MONODITE™	
		MT T (triangle)			
		MT R (round)			
Super-finishing and precision machining e.g. precious metals and MMC materials	MXP	Single crystal high pressure, high temperature (HPHT) diamond - Pale yellow (medium nitrogen content)		MONODITE™	
	MWS PT4				
	MWS PT2				
Dressing	Single point, multi-point, blade, roller and rotary dressing	MDL		MONODRESS™	
	Chisel dressing / chisel form dressing	MM			
Wire drawing	Wire drawing of ferrous, non-ferrous precious and refractory metals	MD	Single crystal HPHT diamond - Pale yellow (medium nitrogen content)		MONODIE™

Key product features	Orientation	Shape availability	Size range	Format
Premium product having a unique combination of high wear and very high thermal conductivity	2 pt / {110} plates 4 pt / {100} plates		Up to 4.0 mm	Polished plates with precise laser cut edges
Polycrystalline CVD with high abrasion resistance and thermal stability. Suitable for dry or MQL machining	Polycrystalline	Primarily rectangles, also squares, triangles and circles*	Available laser cut	Available as grown, lapped or polished
Polycrystalline CVD, electrically conductive to facilitate EDM	Polycrystalline		Available laser or EDM cut	Available as grown, lapped or polished
Highly engineered polished plates, laser cut to specific dimensions	4 pt / {100} plates also available in 2 pt / {110} on request		Typically up to 4 mm edge length and 1.5 mm thickness	Polished plates with precise laser cut edges
Near square plates having guaranteed inscribed square	4 pt / {100} plates	Near square	2 to 4.5 mm edge length and up to 1.5 mm thickness	Defined by inscribed square
Near round plates having guaranteed inscribed circle		Near round		Defined by inscribed circle
Engineered polished plates benefiting from 2 point orientation	2 pt / {110} plates	Near rectangular	Typically up to 3 - 4 mm edge length up to 1.5 mm thickness	Polished plates with defined 2 pt / 4 pt directions
Designed for abrasive wear resistance in dressing and parting tool applications Good thermal stability	4 pt / {100} plates	Rectangular logs and squares	Standard sizes 2.5 to 4.5 mm in length	Polished squares or rectangles with precisely laser cut edges
Alternative to natural diamond macles	3 pt / {111} plates	Triangular / macle shaped. Also available in laser cut triangles up to 3.0 mm edge length	3.0 to 4.5 mm edge lengths	Polished macle plates
Wire drawing die blanks with specific quality controlled inscribed circle Exceptional wear resistance due to 3 pt crystal orientation	3 pt / {111} plates	Hexagonal polyhedra	0.5 to 1.80 mm thickness	Polished die blanks having a guaranteed usable inner volume defined as an inscribed circle

# MONODITE™ MCC:

## Two-point and four-point direction

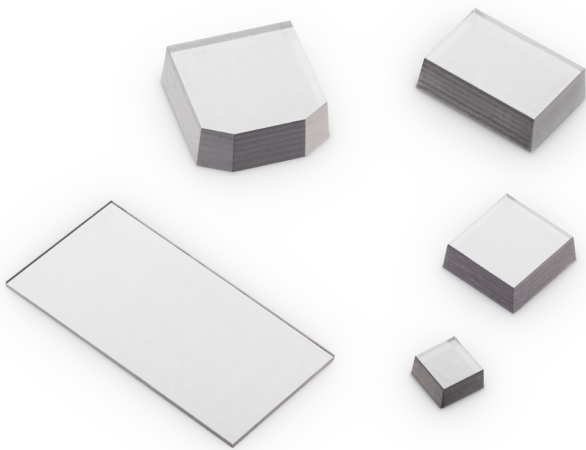

### Features

- Unique combination of extreme wear resistance, excellent chip resistance and high thermal conductivity combined with low thermal expansion
- Produced under ultra-high purity conditions
- Colourless

### Benefits

- High quality surface finishes on abrasive workpiece materials
- Outperforms natural diamond due to its consistent and predictable material properties
- Offers superior edge quality in ultra-precision machining operations

### Tool fabrication

Being an engineered material, MCC is produced in standard sizes that can reduce fabrication times for tool production.

The high chemical purity and consistency also offers potential savings in processing this material. It can be fabricated into finished tools using standard manufacturing technologies including laser cutting, polishing, brazing and grinding.

For further information please refer to our Processing Guidelines.

### Size availability

Product nomenclature	Dimensions (mm) (length x width x thickness)
MCC L453012	4.5 x 3.0 x 1.2
MCC L403012	4.0 x 3.0 x 1.2
MCC L303012	3.0 x 3.0 x 1.2
MCC L302512	3.0 x 2.5 x 1.2
MCC L403010 PT4PT2	4.0 x 3.0 x 1.0

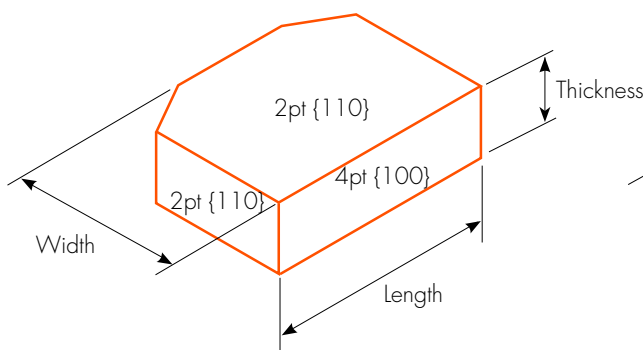

Example of an MCC 2 pt product of nomenclature MCC L403012.  
Length = 4.0 mm, Width = 3.0 mm and Thickness = 1.2 mm.

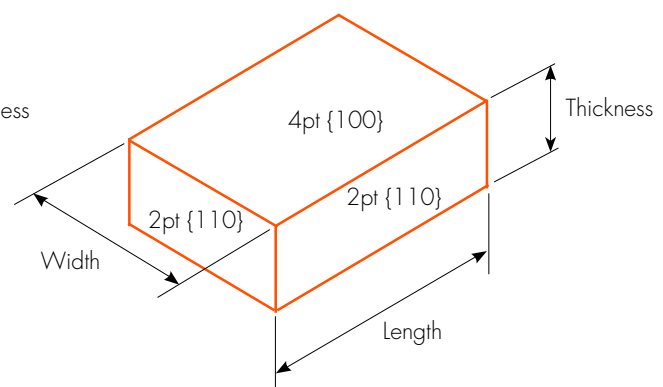

Example of MCC 4 pt 2 pt product nomenclature MCC L403010PT4PT2.  
Length = 4.0 mm, Width = 3.0 mm and Thickness = 1.0 mm.

# CVDITE™: CDM & CDE CVD diamond

## Nomenclature examples

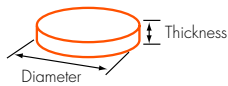

**CDE R**  
CDE R2605-360PL is a CDE grade 'round', 2.6 mm in diameter and 0.5 mm thickness. PL for polished finish

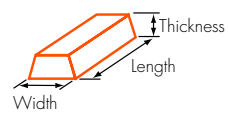

**CDE L**  
CDE L603005PL is a CDE grade, 6.0 mm in length, 3.0 mm wide, 0.5 mm thickness. PL for polished finish

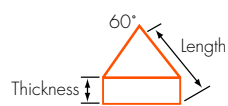

**CDE T**  
CDE T3005-60PL is a CDE grade equilateral triangle having 3.0 mm edge length and 0.5 mm thickness. PL for polished finish

A minimum order charge may be incurred for small volumes of new parts.

### Time to reach 0.2 mm flank wear in continuous outside diameter turning of metal matrix composite (AMC225XE (S))

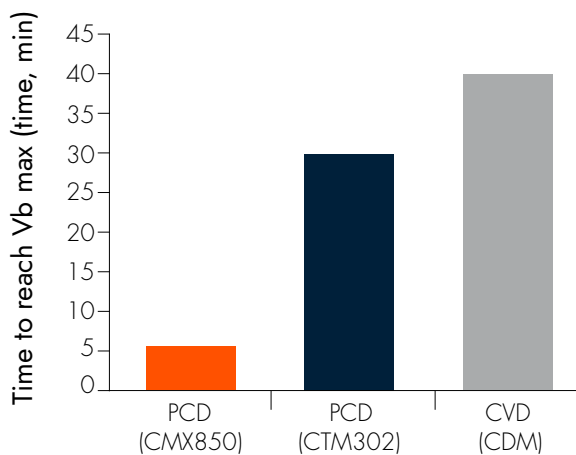

In applications where tool wear is dominated by abrasive wear CVD has been observed to show greater abrasion resistance compared to PCD. Therefore CVD is particularly suitable for highly abrasive continuous turning operations.

#### Definitions

The standard surface finish has a polished face (Ra<100 nm) and a lapped face (Ra<400 nm) designated with the suffix PL. Unprocessed material is also available-designated NP. The surface finish of NP is either 'as grown' or with any finish to meet the specified thickness.

### Features

- High resistance to abrasive wear and high thermal stability
- Chemically inert material
- CDE is electronically conductive

### Benefits

- Improved cutting edge quality and better chip flow characteristics
- Reduced friction for wear parts due to polished surface

### Suggested application

#### CVDITE™ CDE

Cutting tools using electrical discharge machining (EDM) or electrical discharge grinding (EDG)

#### CVDITE™ CDM

General purpose cutting tools



#### CVDITE™ CDE & CDM

Dry machining of metal matrix composites and high volume fraction glass fibre reinforced materials operating at high temperatures

### Tool fabrication

- Typical natural diamond tool fabrication techniques can be applied. Synthesized as flat plates and processed to exact requirements and high standards of the diamond toolmaking industry. Prepared with fine lapped surface preferred for bonding
- Brazing to tungsten carbide substrates can be carried out in a vacuum furnace or reducing gas atmosphere using high temperature active braze alloys
- Highly polished face is recommended for use as the top table or rake face of the tool as beneficial in producing a sharp, chip-resistant cutting edge

### Thickness availability

#### Cvdite (cutting tools)

##### CDE

##### CDM

CDE 05 PL

CDM 05 PL

CDE 05 PL (0.5 mm thick polished).

# MONODITE™ MT: Laser defined shapes

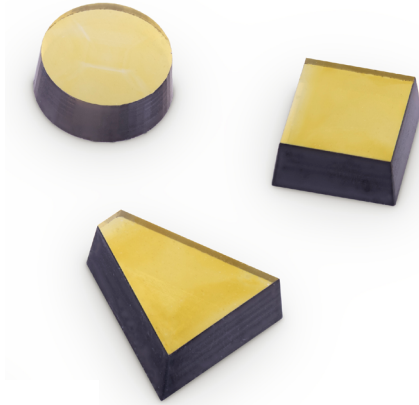

MONODITE™ MT is a highly engineered and tightly specified product.

## Suggested application

- Particularly suited to ultra-precision machining such as super-finishing
- Engineered cutting tools and wear parts for super-finishing, burnishing and wire guides
- Convenient cut shapes

## Features

- Available as 4 pt and 2 pt orientation
- Available in standard cut geometries rectangles, triangles and rounds up to 8 mm maximum edge length and in thickness up to 1.5 mm
- Custom shapes are also available on request
- Produced in standard thickness's 1.0 mm, 1.2 mm, 1.5 mm
- Manufactured by our proprietary high pressure, high temperature synthesis process

## Benefits

- Near net sizes facilitates reduced grinding times in tool manufacture
- Laser cut standard geometries allow ease of replacement for conventional Carbide and PCD turning and milling applications
- Available at volume

## Available sizes

MONODITE™ MTL Product nomenclature	Dimensions (mm) (length x width x thickness)		
MT L403010	4.0 x 3.0 x 1.0		
MT L303012	3.0 x 3.0 x 1.2		
MT L302012	3.0 x 2.0 x 1.2		
MT L301512	3.0 x 1.5 x 1.2		
MONODITE™ MTT Product nomenclature	Dimensions (mm) (edge length x thickness)	Angle (°)	
MT T3012 - 90	3.0 x 1.2	90	
MT T3010 - 60	3.0 x 1.2	60	
MONODITE™ MTT Product nomenclature	Dimensions (mm) (diameter x thickness)	Angle (°)	
MT R2512 - 360	2.5 x 1.2	360	
MT R2012 - 360	2.0 x 1.2	360	

Other sizes available on request including 2 pt and custom products

# MONODITE™ MXP: Four-point direction



Our diamond is engineered in our proprietary synthetic process ensuring material consistency and uniformity at volume.

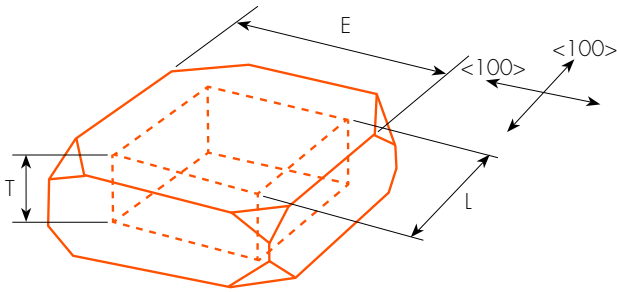

E = Nominal Length T = Nominal Thickness  
L = Edge Length of Inscribed Square (at least 75% of E)  $\{100\}$ , four point stone orientation

## Features

- Premium synthetic diamond supplied in a range of specified dimensions from 3 mm to 4.5 mm (four-point direction) in usable edges length
- Manufactured by our proprietary high pressure, high temperature synthesis process

## Benefits

- Wide range of standard stock sizes
- Guaranteed inscribed square edge length of 75% minimum of the nominal plate length
- Available at volume

## Suggested applications

- General applications
- Super-finishing and precision machining e.g. precious metals and MMC materials

## Available sizes

The large range of available sizes gives toolmakers an increased choice and optimises diamond usage.

Available sizes			
Product nomenclature	Nominal length (mm)	Minimum edge length of inscribed square (mm)	Minimum thickness (mm)
MXP L3010	3.0	2.25	1.0
MXP L3012	3.0	2.25	1.2
MXP L3510	3.5	2.6	1.0
MXP L3512	3.5	2.6	1.2
MXP L4010	4.0	3.0	1.0
MXP L4012	4.0	3.0	1.2
MXP L4510	4.5	3.35	1.0
MXP L4512	4.5	3.35	1.2

Other sizes available on request, including thickness of up to 1.5 mm.

# MONODITE™ MWS: Four-point direction

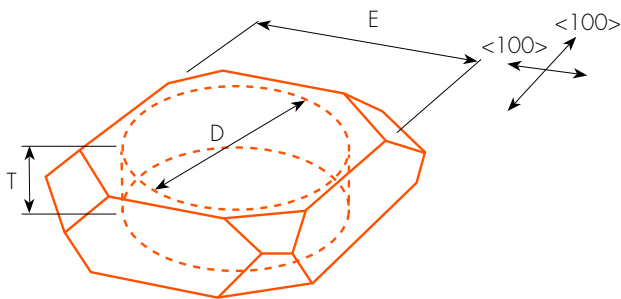
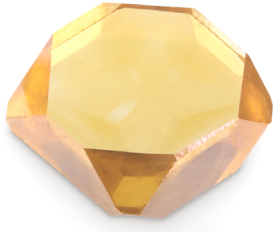

E = Nominal Length T = Nominal Thickness  
D = Diameter of Inscribed Circle (at least 80% of E) {100},  
four point stone orientation

## Features

- Synthetic single crystal diamond supplied in a range of specific dimensions from 2 mm to 4.5 mm in usual edge length
- Manufactured by our proprietary high pressure, high temperature synthesis process

## Benefits

- Wide range of standard stock sizes
- Guaranteed inscribed circle (diameter) of 80% minimum of the nominal plate length
- Available at volume

## Suggested applications

- General applications
- Super-finishing and precision machining e.g. precious metals and MMC materials

## Available sizes

The large range of available sizes gives toolmakers an increased choice and optimises diamond usage.

Product nomenclature	Nominal length (mm)	Minimum inscribed circle diameter (mm)	Minimum thickness (mm)
MWS L2008	2.0	1.6	0.8
MWS L2010	2.0	1.6	1.0
MWS L2508	2.5	2.0	0.8
MWS L2510	2.5	2.0	1.0
MWS L3010	3.0	2.4	1.0
MWS L3012	3.0	2.4	1.2
MWS L3510	3.5	2.8	1.0
MWS L3512	3.5	2.8	1.2
MWS L4010	4.0	3.2	1.0
MWS L4012	4.0	3.2	1.2
MWS L4510	4.5	3.6	1.0

Other sizes available on request, including thickness of up to 1.5 mm.

# MONODITE™ MWS: Two-point direction

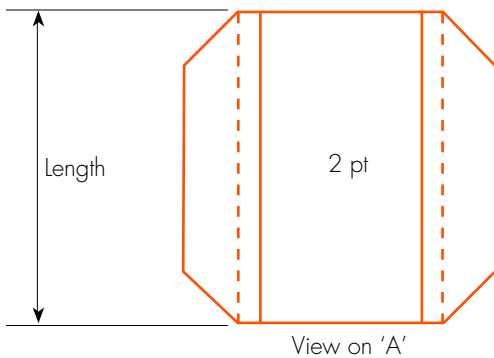
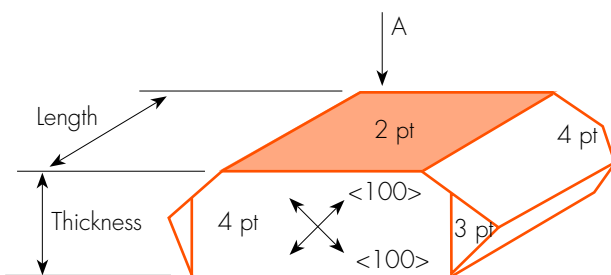

## Features

- Synthetic single crystal diamond supplied in as standard sizes
- Guaranteed window in 2 pt and 4 pt directions
- Manufactured by our proprietary high pressure, high temperature synthesis process

## Benefits

- Wide range of standard sizes with in a range of specific dimensions from 3.0 to 4.0 mm and 1.0 to 1.2 mm thickness
- With increased abrasive resistance, this format provides an ideal alternative to Two-Point natural diamond plates
- Available at volume

## Suggested applications

Particularly suited to ultra-precision machining such as super-finishing in aluminium alloys, acrylic and precious metals.

### Large range of available sizes

Product nomenclature	Edge length (mm)	Thickness (mm)
MWS L3010PT2	3.0	1.0
MWS L3012PT2	3.0	1.2
MWS L4010PT2	4.0	1.0
MWS L4012PT2	4.0	1.2

Other sizes available on request, including thickness of up to 1.5 mm.

# MONODRESS™ MDL: Four-point direction

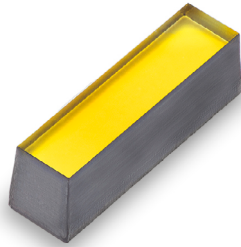

MONODRESS™ MDL is supplied in a range of length and square cross sections which are laser cut to exact dimensions to facilitate tool manufacturers.

Simply by rotating the logs through 45° about their central axis, the two point direction can be revealed, offering the option to make a tool with even greater wear resistance. As the MDL has a constant dresser width, no resetting is needed.

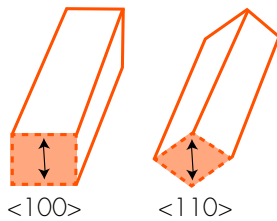

Each product has {100} (four point) orientation on all faces that are easily defined and located with their grinding directions.

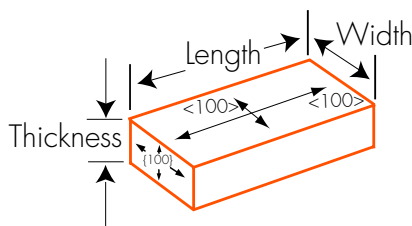

Non-standard dimensions are available by request for this product.

## Tool fabrication

Two methods of tool fabrication are suitable for use with MONODRESS™ MDL – non-ferrous metal sintering or brazing onto a dresser body using an active braze alloy in a non-oxidising environment. Using diamond grinding, the dressers can be shaped in-situ to make cone, chisel and rounded shapes.

## Features

- Supplied as rectangles or square shaped logs in various length
- Excellent thermal stability

## Benefits

- Consistent wear from dresser to dresser
- Uniform wear over the entire length of the dresser
- Easy-to-use toolmaking material
- Constant dresser cross-section - no resetting needed

## Suggested applications

- All dresser types, for example: single point, multipoint and blade dressing
- Developed to offer high resistance to abrasive wear in dressing and parting tool applications

## Size availability

Product nomenclature	Dimensions (mm) (length x width x thickness)
MDL 251212	2.5 x 1.2 x 1.2
MDL 251515	2.5 x 1.5 x 1.5
MDL 300404	3.0 x 0.4 x 0.4
MDL 300606	3.0 x 0.6 x 0.6
MDL 300808	3.0 x 0.8 x 0.8
MDL 301010	3.0 x 1.0 x 1.0
MDL 301212	3.0 x 1.2 x 1.2
MDL 301515	3.0 x 1.5 x 1.5
MDL 400404	4.0 x 0.4 x 0.4
MDL 400606	4.0 x 0.6 x 0.6
MDL 400808	4.0 x 0.8 x 0.8
MDL 401010	4.0 x 1.0 x 1.0

# MONODRESS™ MM 111:

## Three-point direction

### Advantages

- Specific process and quality for use in chisel dressing and chisel form dressing
- All purchased items immediately usable for tools (unlike natural). Size range 3-5 mm edge length
- Consistent 3 pt / (111) orientation
- Available as grown stones but can be laser cut to requirements

### Benefits

- A readily available alternative to natural diamond macles
- Economic volume alternative
- Larger and flatter with less rounding and irregularity than natural
- Enhanced and more consistent performance

### Suggested application

Engineered for chisel form dressing.

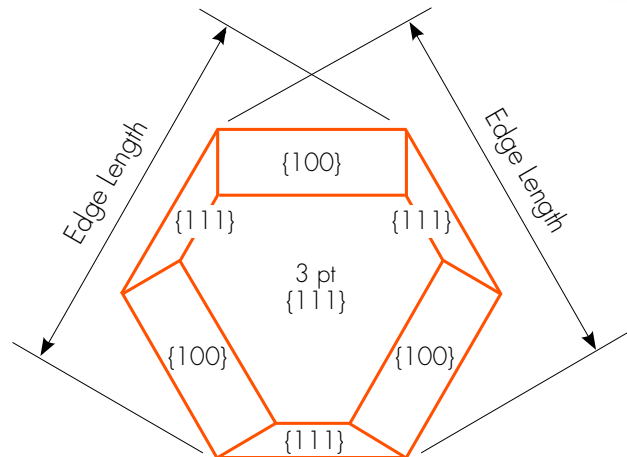

### Size availability

Nomenclature	Edge length	Thickness
MM 111/3010	3.0	1.0
MM 111/3012	3.0	1.2
MM 111/4010	4.0	1.0
MM 111/4012	4.0	1.2
MM 111/4510	4.5	1.0
MM 111/4512	4.5	1.2

Also available as laser cut in thicknesses of up to 1.2 mm.

# MONODIE™ MD111: Three-point direction

In every application from electronics to construction, wire drawing dies are the essential tools used to produce the millions of miles of wire drawn. For applications of drawing non-ferrous, ferrous, precious and refractory metals that require ultra-fine finishes, single crystal diamond is the preferred wire drawing material.

The MONODIE™ synthetic single crystal diamond range of wire drawing die blanks, developed by Element Six takes the unpredictability out of wire drawing applications.

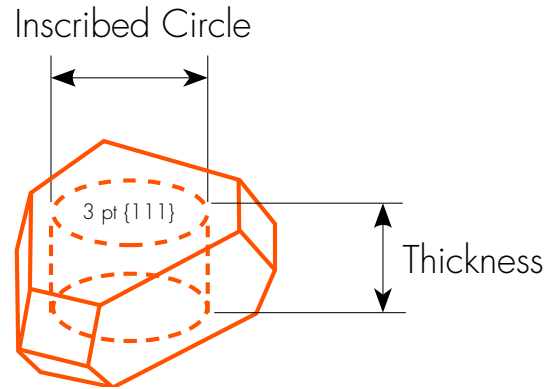

## Features

- High level of product quality and consistency
- Exceptional wear resistance
- High thermal stability
- High thermal conductivity

## Benefits

- Reliable die life, reduced hole wear distortion and optimal die life due to consistent (111) orientation
- High quality finish on drawn wire
- Consistent tool life

## Suggested application

Wire drawing die blank products.

## MONODIE™ MD111

MONODIE MD111 offers the highest level of quality and consistency in wire drawing die blanks. Each diamond blank is produced by a stringently controlled single crystal synthesis process. Properties of the material include exceptional wear resistance resulting from its 3 point {111} crystal orientation. Coupled with excellent thermal conductivity and thermal stability at temperatures up to 1100°C in a non-oxidising environment, the end user benefits are consistent tool life and a high quality finish on the drawn wire.

## Size availability

Nomenclature	Nominal thickness (mm)	Thickness tolerance (mm)	Minimum inscribed circle diameter (mm)
MD111/05	0.5	0.46 - 0.55	0.6
MD111/06	0.6	0.56 - 0.65	0.7
MD111/07	0.7	0.66 - 0.75	0.8
MD111/08	0.8	0.76 - 0.85	0.9
MD111/09	0.9	0.86 - 0.95	1.0
MD111/10	1.0	0.96 - 1.05	1.1
MD111/11	1.1	1.06 - 1.15	1.2
MD111/12	1.2	1.16 - 1.25	1.3
MD111/13	1.3	1.26 - 1.35	1.4
MD111/14	1.4	1.36 - 1.45	1.45
MD111/15	1.5	1.46 - 1.55	1.5
MD111/16	1.6	1.56 - 1.65	1.6
MD111/17	1.7	1.66 - 1.75	1.7
MD111/18	1.8	1.76 - 1.85	1.8



Product solutions  
to suit your needs  
Contact us today





Element Six is a global leader in the development and production of synthetic diamond and tungsten carbide solutions. For 80 years, our innovation expertise has enabled a wide range of industries, from aerospace and mining, to semiconductors and sensing. Part of the De Beers Group, our primary manufacturing sites are located in the US, UK, Ireland, Germany and South Africa.



## Contact us

### Europe

#### Customer Services

T +353 61 460146

E [salesorders@e6.com](mailto:salesorders@e6.com)

### Americas

T +1 281 364 8080

E [ussalesorders@e6.com](mailto:ussalesorders@e6.com)

### Asia Pacific

#### China

T +86 (0)21 6359 5999

E [office.china@e6.com](mailto:office.china@e6.com)

ELEMENTSIX, the e6 logo, CVDITE, MONODIE, MONODITE and MONODRESS are trade marks of the Element Six Group.

[e6.com](http://e6.com) | [e6cvd.com](http://e6cvd.com)